

Raindance Select E

Shower holder set 120 3jet with shower hose 160 cm

Surfaces: **White/Chrome** Article Number: **26720400**



Description

product features

- consists of: hand shower, shower holder, shower hose
- spray type: RainAir, Rain, Whirl
- convenient diversion via Select button
- pivot connectors prevent hose from tangling
- maximum flow rate at 0.3 MPa: 15 l/min
- wall supports of plastic

Technology



Product image



Scale drawing

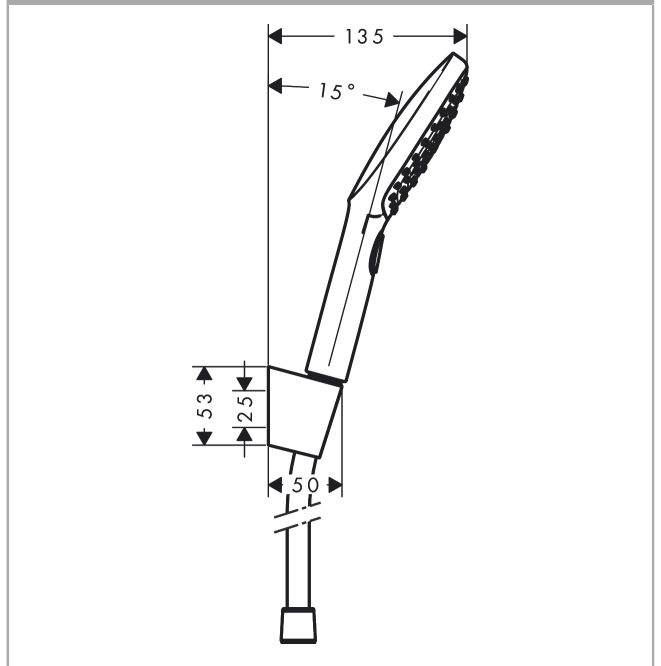

Flowchart

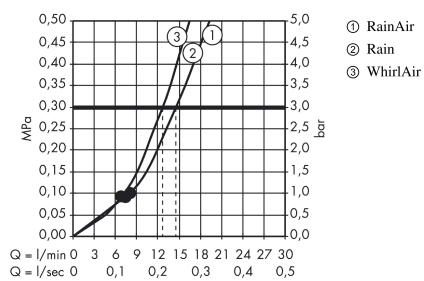

The consumption was measured in combination with the appropriate fittings (thermostat/mixer/ in-wall valve) to reflect actual application in practice.